

PCI express Bus 4-Axis Motion Control Board with interpolation

PbFree

MC8043Pe is a PCI express x1-bus compliant PC/AT compatible circuit board equipped with 4-axis motion control IC with interpolation function "MCX314As". It can independently control 4-axis of either stepper motor or pulse type servo motor for position and speed controls. In addition, this IC can perform 2/3 axes linear interpolation, CW/CCW circular interpolation and 2/3 axes bit pattern interpolation(interpolation by bit data from CPU).

● Circular/Linear interpolation

MC8043Pe calculates circular/linear interpolation by hardware in MCX314As. Setting each parameter, finish and center point of circle and speed, writing the command of interpolation drive, it operates interpolation drive immediately. Setuptime for calculating is not needed. It can perform continuous interpolation combined circular/linear interpolation as the lower-right figure, "Example of continuous interpolation."

● Max driving speed:4Mpps

Each axis can perform Max.4Mpps in acceleration/deceleration drive and circular/linear interpolation drive.

● S-curve Acceleration/Deceleration

In addition to trapezoidal acceleration/deceleration drive, it can also operate s-curve drive. S-curve drive can keep its smoothness as the right figure "Example of S-curve Acceleration/Deceleration". Even though the number of output pulse is small.

● Compatible with MC8043P

Compatible with PCI-bus board, MC8043P.

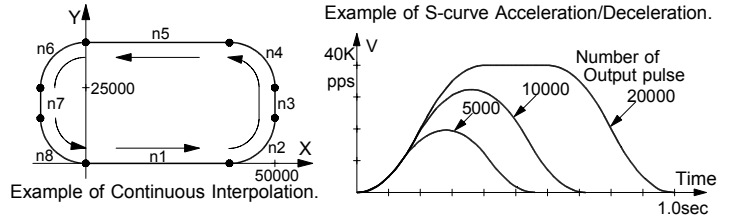
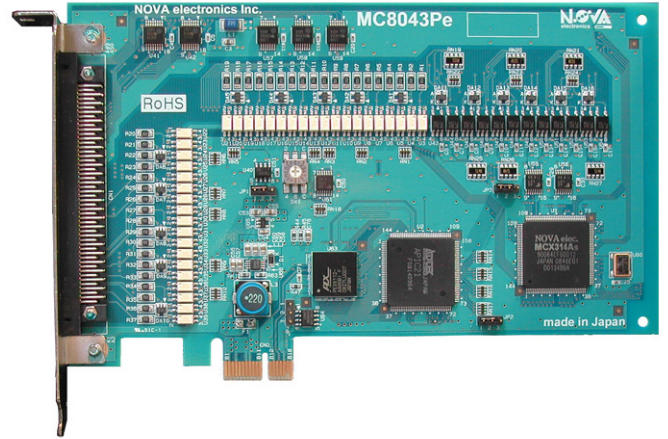

Circuit Block Diagram and I/O Signal

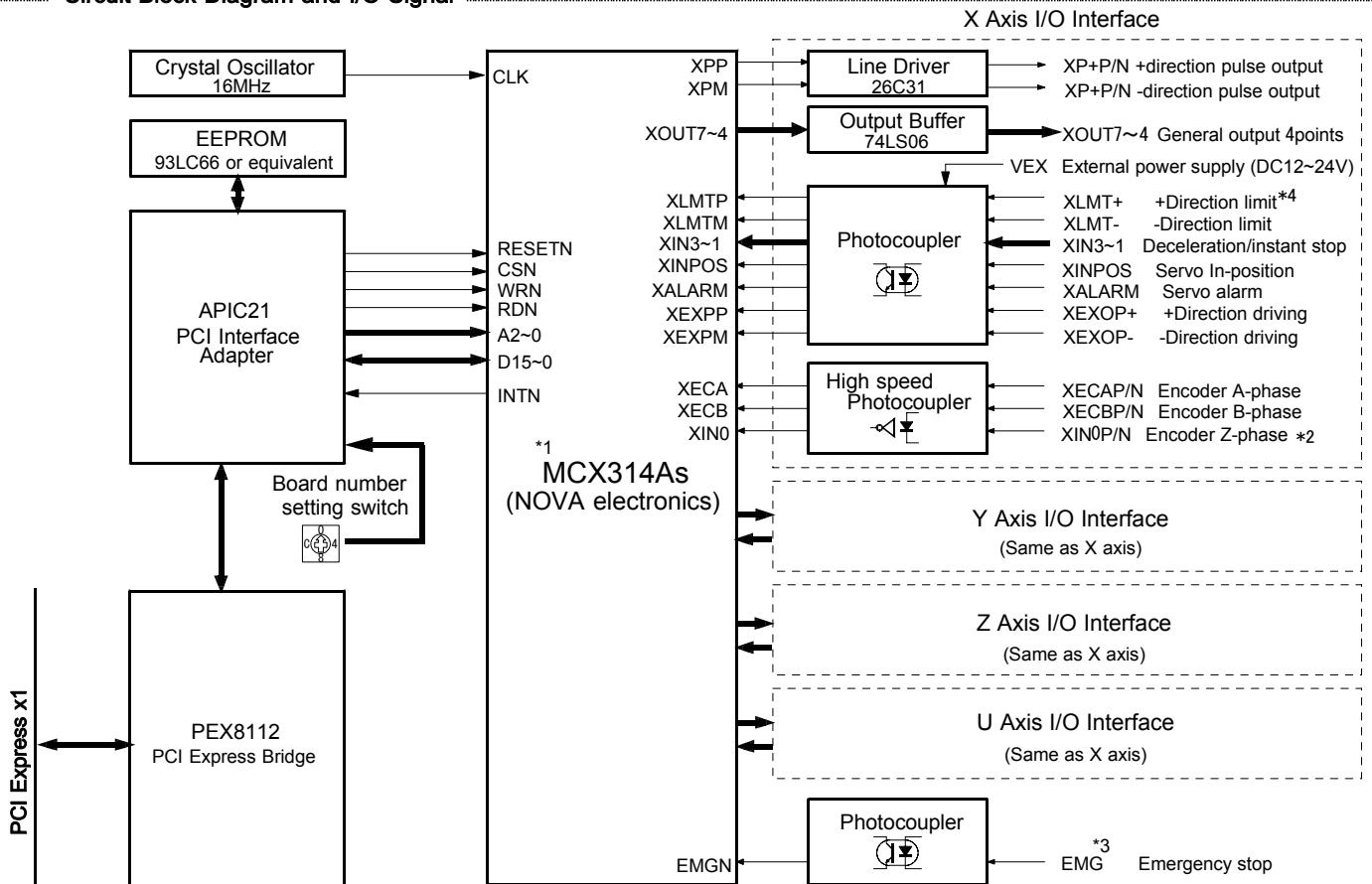

*1 Regarding MCX314As, please refer to the catalog and user's manual of MCX314As. MC8043Pe does not support the following signals of MCX314As, BUSYN, EXPLSN, SCLK, nDRIVE, nOUT3~0.
 *2 Encoder Z-phase input signal can be input to nIN2 of MCX314As by switching jumper.
 *3 Emergency stop input signal can change the logic by switching jumper.
 *4 MCX314As built-in integral filter ($\tau=512\mu\text{sec}$) is set to all the input signals (nECA/B excluded) of I/O interface by Windows device driver default setting.

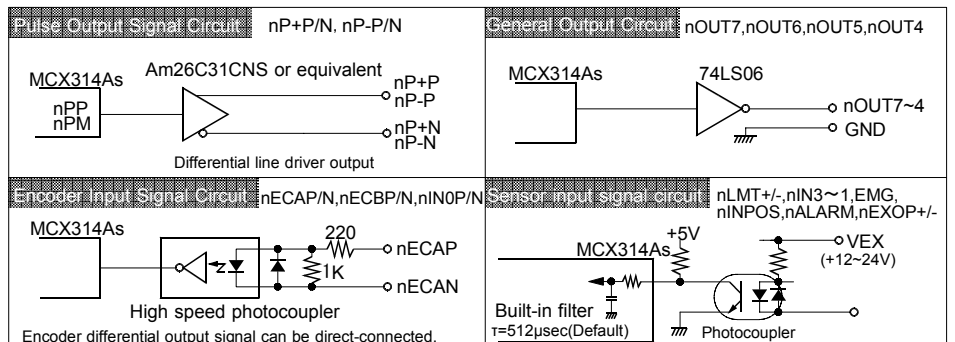

Specifications

■ Control Axis	4 axes
■ Interface	PCI Express ×1
■ Data bit width	16 bit
■ Occupied I/O Address	16 byte Address is determined by PnP
■ Interrupt	IRQ Connected by PnP.

Interpolation

■ 2/3-axis linear interpolation

- Range : each axis -2,147,483,646~+2,147,483,646
- Speed : 1 ~ 4 MPPS
- Position accuracy : ±0.5LSB(Within the range of whole interpolation)

■ Circular interpolation

- Range : each axis -2,147,483,646~+2,147,483,646
- Speed : 1 ~ 4 MPPS
- Position accuracy : ±1 LSB(Within the range of whole interpolation)

■ 2/3-axis bit pattern interpolation

- Speed : 1 ~ 4 MPPS
(Dependent on CPU data writing time)

■ Other functions

- Selectable any axis
- Constant vector speed
- Continuous interpolation
- Single step interpolation

Common specifications of each axis

■ Drive pulse output

- Output circuit : Differential line-driver (26C31) output
- Speed range : 1 PPS ~ 4 MPPS
- Speed accuracy : ±0.1%(according to the setting value)
- S-curve jerk : $954 \sim 31.25 \times 10^9$ PPS/SEC²
- Acc./Dec. speed : $125 \sim 500 \times 10^6$ PPS/SEC
- Drive speed : $1 \sim 4 \times 10^6$ PPS
- Output pulse number : 0 ~ 4,294,967,295/unlimited
- Speed curve :
Constant/Symmetrical·Non-symmetrical trapezoid/
Symmetrical·Non-symmetrical S-curve
- Fixed Pulse Drive Deceleration Mode : Auto/Manual deceleration
- Output pulse number and drive speed are changeable during driving.
- Independent 2-pulse or 1-pulse 1-direction system is selectable.
- Logical levels of dirve pulse is selectable.

■ Encoder A/B/Z phase input

- Input circuit :
High speed photocoupler input, connectable with differeicial line-driver.
- 2-phase pulse style or up/down pulse style is selectable.
- 2-phase pulse
Pulse of each single, double or quad counter evaluation edge is selectable.

■ Position counter

- Logical position counter (for output pulse) Bit length:32bit
- Real position counter (for input pulse) Bit length:32bit
To write and read data is always possible.

■ Comparison register

- COMP+ register/COMP- register
- Status and signal outputs for the comparisons of position counters
- To work as Software limit.

■ Automatic home search

- Step1(High speed near home search)→Step2(Low speed home search)
→Step3(Low speed encoder z-phase search)
→Step4(High speed off-set drive)
Enable/disable of each step and search direction is selectable.

■ Interrupt(Interpolation excluded)

- The factors of occuring interrupt:
..drive-pulse outputting
..start / finish of a constant-speed drive during the acceleration/deceleration driving
..end of the driving
..Transition to "the volume of position counter ≥ the volume of COMP-"
..Transition to "the volume of position counter < the volume of COMP-"
..Transition to "the volume of position counter ≥ the volume of COMP+"
..Transition to "the volume of position counter < the volume of COMP+"
..terminating of automatic home search, synchronous action
Enable/disable for these factors is selectable.

■ Synchronous action

- Activation factor: Transition to "position counter ≥ COMP+", Transition to "position counter < COMP+", Transition to "position counter < COMP-", Transition to "position counter ≥ COMP-", start of driving, termination of driving, IN3 signal ↑, IN3 signal ↓, LP read command, activation command.
- Action: Start of +/- fixed pulse drive, start of +/- continuous pulse drive, drive decelerating stop, drive instant stop, saving position counter values, setting position counter values, setting an output pulse number, setting a drive speed and interrupt.

■ External signal for driving

- EXPP and EXPM signals for +/- direction fixed pulse/continuous drive
- Input Circuit : Photo coupler and IC built-in integral filter

■ External deceleration/instant stop signal

- IN0 ~ 3 4 points for each axis (IN0:encoder Z-phase input)
- Input Circuit: Photo coupler and IC built-in integral filter (IN0: high-speed photo coupler input)

Enable/disable and logical levels is selectable.

■ Servo motor input signal

- ALARM (Alarm), INPOS (In Position Check)
- Input Circuit : Photo coupler and IC built-in integral filter
Enable/disable and logical levels is selectable.

■ General output signal

- OUT4 ~ 7 4 points for each axis
(General output and drive status output can be switched.)
- Output Circuit 74LS06 output(open collector output)

■ Driving status signal output

- ASND(speed accelerating), DSND(speed decelerating), CMPPP(position ≥ COMP+), CMPPM(position < COMP-)
Drive status is readable by status registers.

■ Limit signal input

- 1 point, for each +/- direction.
- Input Circuit Photo coupler and IC built-in integral filter
Logical levels and decelerating/instant stop is selectable.

■ Emergency stop signal input

- EMGN 1 point for all axes. Stop drive pulse immediately for all axes.
- Input Circuit : Photo coupler and IC built-in integral filter.
Logical levels is selectable by jumper on the board.

Software

■ WindowsXP,Vista, 7

- MC8000P device driver
- Evaluation tool program
- VC++,VB,C# sample program

Software and user's manual are not attached with MC8043Pe.
Please contact us if you need these. Or you can download thee on our website.
<http://www.novaelec.co.jp/eng/index.html>

Others

- **Temperature range for operation:** 0°C~+45°C(no condensation)
- **Power voltage:** +3.3V ±5% (Consumption current 1000 mA max)
- **External supply voltage:** +12~24V
- **Dimension:** 174.6×106.7 mm(Conectors and braket are excluded.)
- **I/O connector:** FX2B-100PA-1.27DS(HIROSE)
- **Accessories:** FX2B-100SA-1.27R (HIROSE) with 1.2m cable

WindowsXP, WindowsVista and Windows7 are registered trademark of Microsoft Corporation.
The Specifications are subject to change without notice due to the technical development. 2013.2

Distributor



达格美(上海)集成电路有限公司
TAKUMI (SHANGHAI) INTEGRATED CUICUIT CO.,LTD.

地址:上海市浦东新区张杨路188号汤臣中心B栋801室
电话:021-5840-8299 E-mail:dgmsh@takumi-hkg.com
传真:021-5840-1590 WEB:www.takumi-sh.com



3F,Grand Axe Bldg.,1-7-20 Uehara,Shibuya-Ku,Tokyo 151-0064,Japan
WEB SITE http://www.novaelec.co.jp/eng/index_e.html
EMAIL ADDRESS novaelec_info@novaelec.co.jp
TEL 81-3-5738-3666 FAX 81-3-5738-3665